

# PERTRONIC INDUSTRIES LTD

## INSTALLATION DATASHEET

### PSB Sounder Base (PSBAS2220, PSBAS2220-AT)



#### Overview

Pertronic Sounder Bases (PSBAS2220, PSBAS2220-AT) are sounders with built in analogue addressable plug-in detector bases.

The sounder bases communicate with any Pertronic analogue addressable fire alarm control panel via the analogue addressable signalling circuit (loop). When the detector is active in the alarm state the sounders will generate a tone, as follows:

- » PSBAS2220: Evacuation tone
- » PSBAS2220-AT: Alert tone

Pertronic Sounder Bases may be connected to supervised bell or sounder circuits. If the bell (sounder) circuit is reversed when the detector is normal, the sounder generates an evacuation tone.

These products are usually flush-mounted by recessing them into the ceiling. A mounting ring is available for surface mounted applications

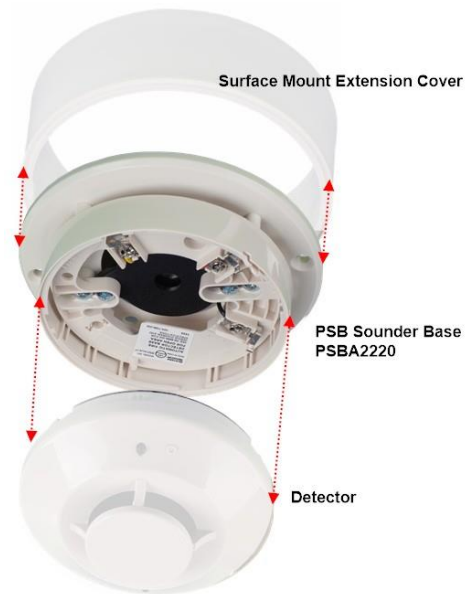

PSBAS2220

#### Features

- » Both products generate the NZS 4512:2010 evacuation tone without verbal message when the bell (sounder) circuit is active
- » With the detector active, and the bell (sounder) circuit inactive, the sounder-bases generate the following tones:
  - » PSBAS2220: NZS 4512:2010 Appendix F evacuation tone without verbal message
  - » PSBAS2220-AT: NZS 4512:2010 Appendix F alert tone without verbal message
  - » 95 dBA maximum sound pressure level
  - » On-board DIP switch allows local alarm tone to be configured as alert or evacuation

#### Specification

Dimensions			
	Height below ceiling, when recessed	31 mm (incl. B501AUS base)	
	Height above ceiling, when recessed	38 mm	
	Diameter of mounting flange	125 mm	
	Surface mounted extension cover	40 mm height	
	Height below ceiling with surface mounted extension cover	71 mm	
Colour		Ivory	
Sound Level Output			
	Sound pressure level at 1 m ( $\pm 3$ dB)	87 dBA (15 V)	NZS 4512:2010 (App F) alert & evacuation tones without verbal message
		95 dBA (24 V)	
Power Requirements			
Analogue addressable loop connection only			
	Operating Voltage	15 to 30 Vdc	
	Quiescent current (non-alarm)	1.2 mA (24 V) (analogue addressable loop)	
	Operating current (alarm state)	5 mA average	7 mA peak (15 V)
		12 mA average	18 mA peak (24 V)
BELL Driver connected (with analogue addressable loop)			
	Quiescent current (non-alarm)	1.2 mA (24 V) (analogue addressable loop)	
		0.2 $\mu$ A (24 V) (BELL driver)	
	Operating current (alarm state)	12 mA average	14 mA peak (15 V)
		19 mA average	25 mA peak (24 V)
<b>Note:</b>	Operating current sourced from the bell circuit when bells activated.		

# Sound Pressure Distribution (24 V)

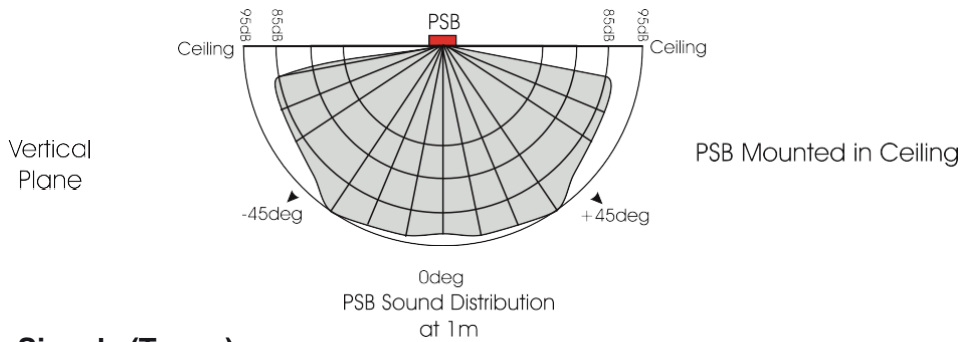

## Audible Alarm Signals (Tones)

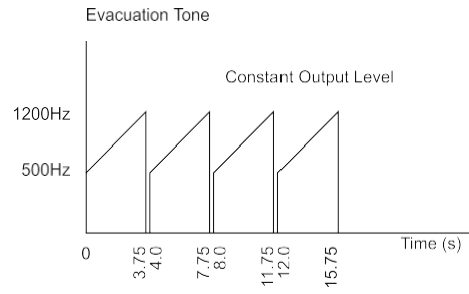
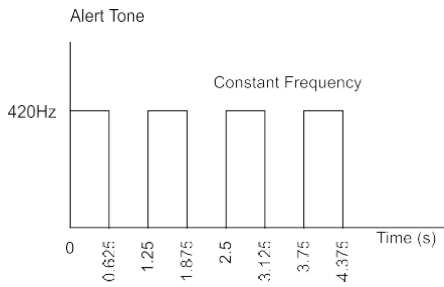

## Operation

The PSB may be powered from the loop (without an external supply) for applications requiring local activation of sounders only. Groups of up to 5 sounder bases may be connected so that all the sounders in the group are activated when at least one of the detectors within the group goes into alarm.

The PSB may also be powered from the panel bells or other bell driver for applications requiring global activation of sounders. The external bell circuit voltage is applied in reverse for fault monitoring (supervision) purposes and to supply power for local activation of the sounders. When a global warning is required, the bell voltage is applied with correct polarity, activating all the sounders connected to the bell circuit.

Some bell driver circuits can generate a pulsed output. When used with the PSB Sounder Base, this pulsed output provides an alternative alert signal based on the evacuation tone. The alternative alert signal complies with NZS 4512:1997.

The sequence is	3.5 seconds – evacuation tone	(one cycle)
	12 seconds – silence	
	3.5 seconds – evacuation tone	
	12 seconds – silence	(repeated)

Group activation of sounders is achieved by connecting a common wire to terminal 3 of each of the detector bases in the group. A maximum of 5 detectors may be connected to form a group. If any detector in the group goes into alarm, the sounders of all the grouped sounder bases are activated (see also page 4).

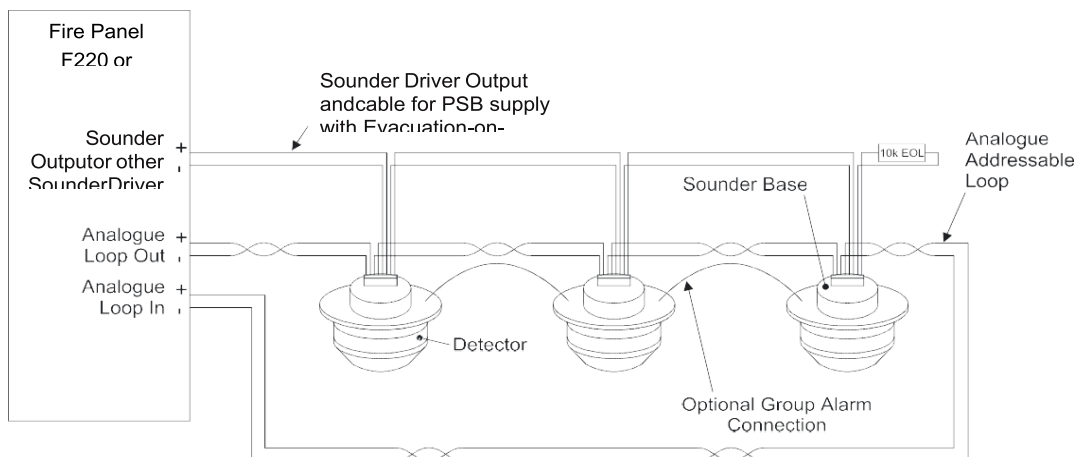

Figure 1: General Loop Sounder Connection

## Local Activation

Figure 2 shows how the sounder bases are connected for local activation. In this arrangement, the sounder associated with the detector on the base is activated when the detector goes into alarm. Table 1 shows whether the alert or evacuation tone is produced.

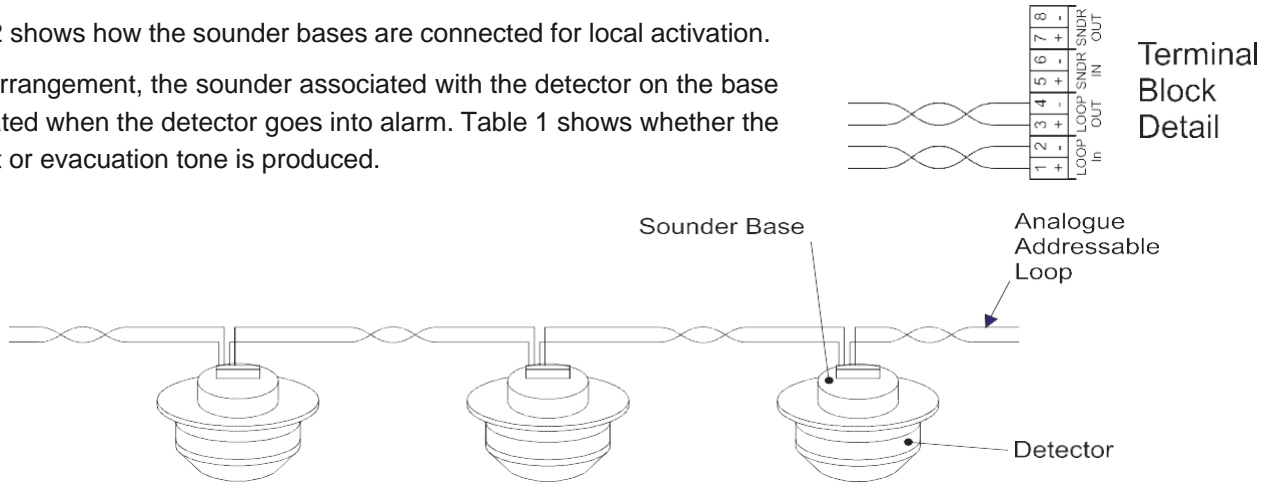
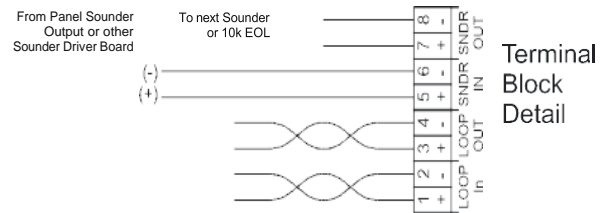

Figure 2: Loop Powered Sounder Bases

## Combined Local and Global Activation

Figure 3 illustrates the connection method for externally powered Sounder Bases. In addition to being connected to the loop, the PSB is also connected to the panel bells or to a zonal bell driver board. The terminals marked '+' and '-' of the **Apartment Sounders** connector of the bell circuit are connected to the '+' and '-' terminals respectively of **SNDR IN** and **SNDR OUT** of the Sounder Base terminal block.



Power is applied with reverse polarity to the Sounder Base when the system is normal. (Supply +ve is connected to terminals 6 and 8, and supply -ve is connected to terminals 5 and 7 of SNDR IN and SNDR OUT of the terminal block).

If the polarity of the supply is changed so that supply +ve is connected to the **SNDR IN** and **SNDR OUT** '+' terminals, and the supply -ve to the **SNDR IN** and **SNDR OUT** '-' terminals, all Sounder Bases will activate their sounders. This provides global evacuation.

A 10k ohm end of line resistor is required at the end of the bell circuit for fault monitoring (supervision).

PSBAS2220			PSBAS2220-AT		
	Bells inactive	Bells active		Bells inactive	Bells active
<b>Detector active</b>	Evacuation Tone	Evacuation Tone	<b>Detector active</b>	Alert Tone	Evacuation Tone
<b>Detector inactive</b>	No Action	Evacuation Tone	<b>Detector inactive</b>	No Action	Evacuation Tone
<b>SW1 Position</b>	Down		<b>SW1 Position</b>	Up	
<b>Old model board</b>	(PCB version <2.0), MJ1 Link OUT		<b>Old model board</b>	(PCB version <2.0), MJ1 Link IN	

Table 1: Tone generation modes (for software version 1.08 and above)

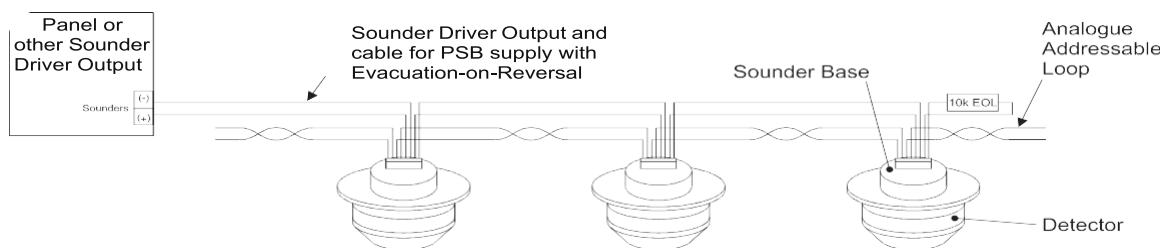

Figure 3: Externally Powered Sounder Bases

## Group Connection of Sounder Bases

Group activation of sounders is achieved by connecting a common wire to terminal 3 of each of the of the detector bases in the group to each other. A maximum of 5 detectors may be connected together to form a group. If any detector in the group goes into alarm, the sounders of all the grouped sounder bases are activated.

The terminal block at the top of the Sounder Base does not have a terminal for group connection, so this must be done by directly connecting terminal 3 of each Sounder Base together.

The group wiring is normally taken between Sounder Bases above the ceiling, requiring the cable to be routed from the Detector base through the sounder base assembly into the space above the ceiling.

The B501 base has an access hole near terminal 1 of the base. The group cable may be taken through that hole (refer to figure 4), and then through an access hole that must be drilled in the sounder housing immediately above the base access hole (see figure 5).

Group wiring may be used for either loop-powered or externally powered configurations.

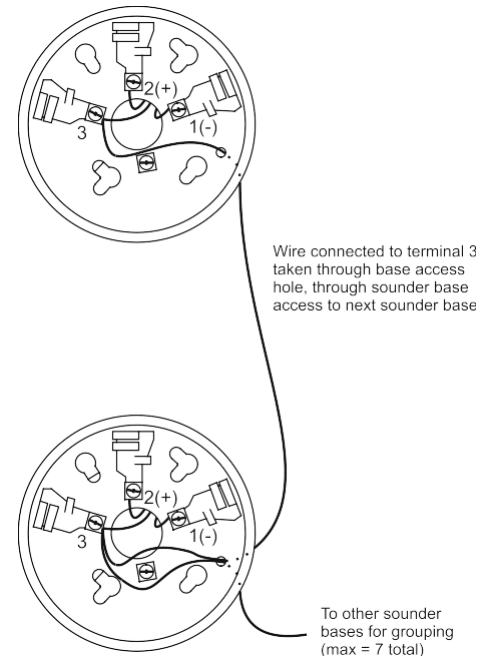

Figure 4: Group Connection

## Mixing Sounder Types

PS2 sounders may be connected to a group of PSB sounders so that the detector alarm can be broadcast in near locations where there are no sounder bases.

Because of electrical loading, there are limitations to the number and type of sounder that may be connected together. These limits are shown in the table:

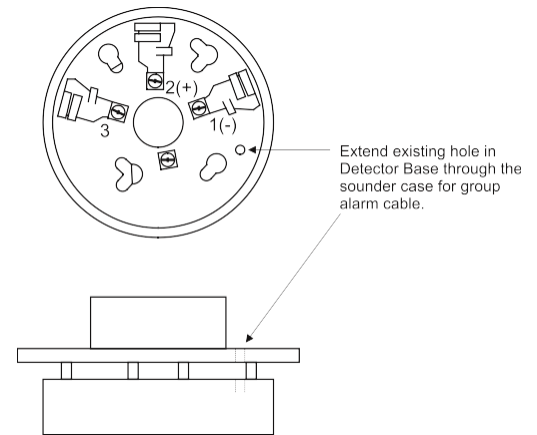

Figure 5: Sounder Housing Access Hole

### Limits to the number of PS2s that may be connected to groups of PSBs

Up to	5 PS2s	4 PS2s	2 PS2s	2 PS2s	2 PS2s
May be connected to a group of	1 PSB	2 PSBs	3 PSBs	4 PSBs	5 PSBs

The PS2s will not sound synchronously with the PSBs.

## Ordering Information

Product Code	Description
PSBAS2220	Pertronic Sounder Base
PSBAS2220-AT	Pertronic Sounder Base with Alert Tone

The information in this document must not be treated as partial or complete instructions for the design, construction, installation, commissioning, or maintenance of fire detection, fire alarm, or building evacuation systems. Fire and evacuation systems must be designed and installed by properly qualified persons, in accordance with all regulatory requirements. Unless explicitly stated otherwise, this document provides typical specifications and nominal dimensions. Actual product performance and dimensions may vary.

All information in this document is subject to change. Please consult Pertronic Industries or visit our web site for upto date information.

PERTRONIC® is a registered trademark of Pertronic Industries Limited.