

Model LASS-BSO-NC

Addressable Base Sounder

Xi'an System Sensor Electronics Ltd.
28 Tuanjie South Road
Xi'an Hi-tech Development Zone
710075, China

Tel: (+ 86) 029 85387800 Fax: (+ 86) 029 88332959

SPECIFICATION

Item	Parameter Description	Note
Operating Voltage	24VDC(15 to 32VDC)	
Avg. Standby Current	< 400µA	24VDC, No Communication, No sounding
Alarm Current	< 6mA	High Volume, 24VDC
	< 4mA	Low Volume, 24VDC
Operating Temp	-10°C to +55°C	
Humidity	10 to 95% R.H.	Non-condensing
Ingress Protection	IP21C	
Approved Sound Pressure Level	83 ± 4dB(A)	1m , High Volume, Tone 21 @24V(2.7mA) * Approved to EN54-3
High Volume . Most Favorable Sound Pressure Position	92 ± 3dB(A)	1m , 90° ,High Volume, Tone 21 @24V(2.7mA) **
	94 ± 4dB(A)	1m , 90° ,High Volume, Tone 13 @24V(3.0mA) **
	95 ± 3dB(A)	1m , 90° ,High Volume, Tone 12 @24V(2.5mA) **
	94 ± 7dB(A)	1m , 90° ,High Volume, Tone 19 @24V(2.5mA) **
Low Volume . Most Favorable Sound Pressure Position	88 ± 3dB(A)	1m , 90° , Low Volume, Tone 21 @24V(2.0mA) **
	88 ± 3dB(A)	1m , 90° ,Low Volume, Tone 13 @24V(2.0mA) **
	85 ± 4dB(A)	1m , 90° ,Low Volume, Tone 12 @24V(1.7mA) **
	85 ± 5dB(A)	1m , 90° ,Low Volume, Tone 19 @24V(1.8mA) **
Tone Type	4	See table 1: 'Sound setting ' for detailed tones
Height	52mm	
Diameter	122mm	
Weight	196 ± 6g	
<p>Note: * Detailed description see table A **These volume & tone settings are not approved to EN54-3.</p> <p>Meet the following Standards requirements: EN54-3 , AS ISO 7240.3:2014</p>		

Before installing and using the product, please read the system wiring and installation manual thoroughly. If the products will be installed in an existing operational system, inform the operator and local authority that the system will be temporarily out of service, disconnect power to the control panel before installing the products.

NOTICE: This manual should be left with the owner/user of this equipment.

GENERAL

LASS-BSO-NC is an intelligent addressable AV base designed to alarm sound for emergency events, and be able to communicate with control panel by intelligent protocol.

It is designed specifically for analogue addressable fire alarm system and only can be connected to control panels with a compatible proprietary analogue addressable communication protocol. It is powered from the loop and can be controlled via the communication protocol(s). The Base version is compatible with 200 series of detectors and B501 mounting base. Up to 99 addresses are available via two rotary selector switches. The sounders have 2 volume levels (high/low) and 4 tone sets. The alarm sound can be tested on field.

INSTALLATION

It must be installed and wired with B501 mounting base.

1. Verify the product type matches with product drawing.
2. Set the address via two rotary selector switches. Please refer to "Address setting".
3. Volume and tone setting are realized by 4 digit DIP switch. On field testing can be tested via DIP switch.
4. Plug the Sounder base into B501 mounting base.
5. Turn the Sounder base clockwise until it drops into place.
6. Continue turning the Sounder base clockwise to lock it in place.
7. Please refer to Detector Installation Instruction if 200 series detector is needed.

SETTING

Address setting

Rotary-decade switches are provided for setting the base's address whose range is from 1 to 99. (Default address is 01). Address is set by turning the switches.

Address is calculated as below formula: Address = TENS *10 + ONES*1. For instance: Address 05 = 0*10 + 5*1.

Tamper-resistant capability

Addressable Base sounder include a tamper-resistant capability that prevents its removal from the B501 base and the removal of installed detector without the use of a tool.

When B501 mounting base enables tamper-resistant function, special tools must be used to disassemble addressable base. Please refer to below figure: use straight screwdriver to break specific position, then insert the screwdriver and maintain in its position. Then you can disassemble the Sounder base by turning anticlockwise

Figure 1

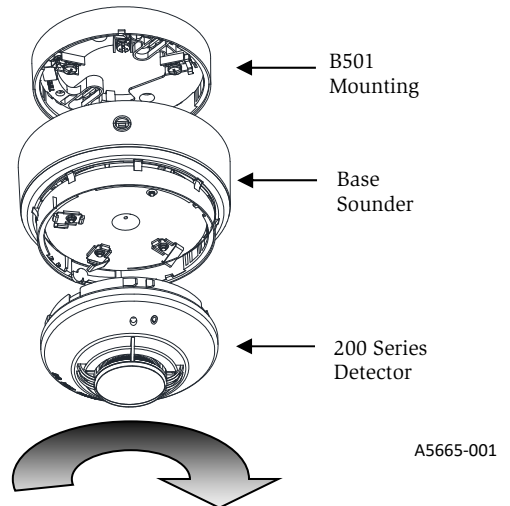

Figure 2

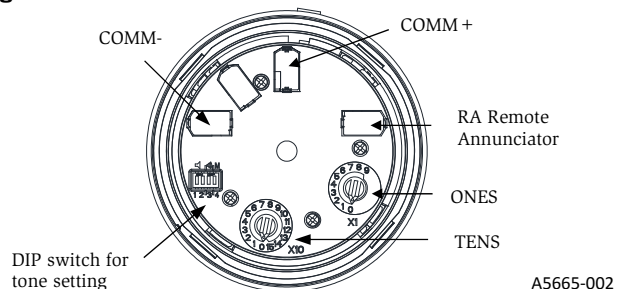
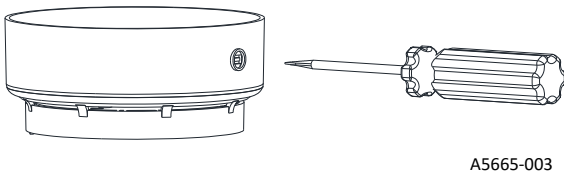
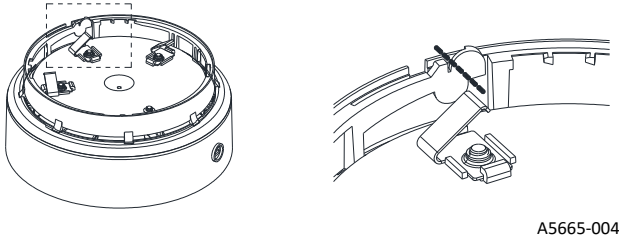

Figure 3



Addressable base has an optional tamper-resistance capability. When it is enabled, installed 200 series detector cannot be removed. To enable this feature, Diagonal pliers can be used to twist the break tab at dotted line toward center of base.

Figure 4



Synchronization

When addressable base send out a fire alarm, control panel can send out a certain signal to synchronize all the addressable AV in same loop to send out fire alarm signal.

Note: Please dispose electronic waste following national or local regulations after being scrapped or replaced. Do not discard.

THREE-YEAR LIMITED WARRANTY

Xi'an System Sensor warrants its enclosed product to be free from defects in materials and workmanship under normal use and service for a period of three years from date of manufacture. Xi'an System Sensor makes no other express warranty for the enclosed product. No agent, representative, dealer, or employee of the Company has the authority to increase or alter the obligations or limitations of this Warranty. The Company's obligation of this Warranty shall be limited to the replacement of any part of the product which is found to be defective in materials or workmanship under normal use and service during the three year period commencing with the date of manufacture. After phoning Xi'an System Sensor for a Return Authorization Number and faxing a copy of the filled CUSTOMER RETURNS with authorized RA# to Xi'an System Sensor, send Defective units with a copy of the form postage prepaid to: Xi'an System Sensor Electronics, Ltd./ 28 Tuan Jie South Road/ Xi'an National Hi-tech Industrial Development Zone, 710075/ China. Please include a note describing the malfunction and suspected cause of failure. The Company shall not be obligated to replace units which are found to be defective because of damage, unreasonable use, modifications, or alterations occurring after the date of manufacture. In no case shall the Company be liable for any consequential or incidental damages for breach of this or any other Warranty, expressed or implied whatsoever, even if the loss or damage is caused by the Company's negligence or fault. Some states do not allow the exclusion or limitation of incidental or consequential damages, so the above limitation or exclusion may not apply to you. This Warranty gives you specific legal rights, and you may also have other rights which vary from state to state.

Figure 5 System wiring diagram

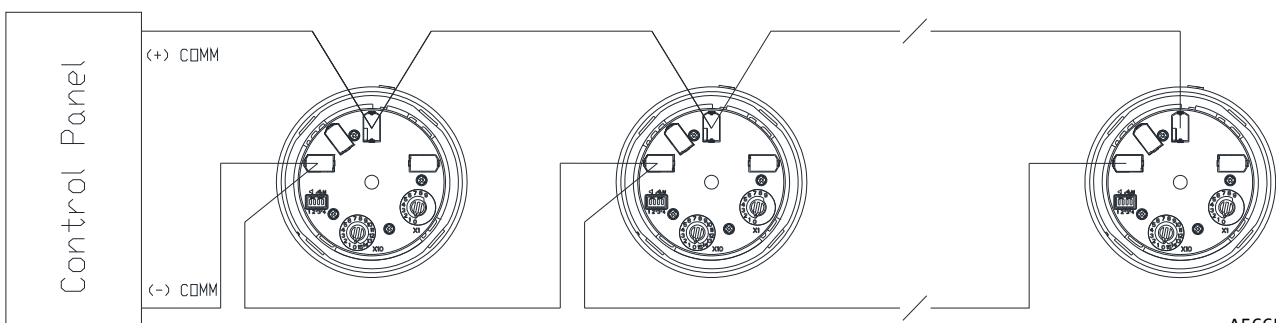

A5665-005

Table 1: Sound setting

	Bit: 1, 2, 3, 4 (0 = off/1 = on/X = random)	Description
Tone setting	0 0 X X	Tone 21(second stage: tone 12)
	0 1 X X	Tone 13(second stage: tone 12)
	1 0 X X	Tone 12(second stage: tone 13)
	1 1 X X	Tone 19(second stage: tone 12)
Volume setting	X X 1 X	High volume
	X X 0 X	Low volume
Test setting please set to 0 under normal use	X X X 1	Field testing on
	X X X 0	Field testing off

Table A

Operational Performance: Tone 21 (High Volume)			Sound Pressure Level dBA
			LASS-BSO-NC
			1m
Horizontal	15Vdc	15°	79.0
		45°	80.3
		75°	87.6
		105°	86.9
		135°	80.4
	32Vdc	15°	79.0
		45°	82.6
		75°	87.6
		105°	87.3
		135°	80.5
Vertical	15Vdc	15°	80.5
		45°	81.3
		75°	87.5
		105°	87.0
		135°	80.8
	32Vdc	15°	80.2
		45°	81.5
		75°	87.8
		105°	87.1
		135°	80.9
		165°	80.3