

Product Guide**C 2142** 200mm (8") 100V High Power 15W Ceiling Speaker

C 2142 High Power One-Shot® EWIS Ceiling Speaker

- ✓ High power output
- ✓ Excellent speech intelligibility
- ✓ High quality speaker driver developed for BGM, paging and emergency warning applications
- ✓ Patented 6 way latching ensures a neat, sag free installation.
- ✓ Fitted with 4 way wire protect terminal block for loop in, loop out wiring as required by Australian Standards.
- ✓ Fitted with supervisory capacitor for line monitoring.
- ✓ High impact styrene grille.
- ✓ 5 year warranty.



Application

The C 2142 is a high power PA speaker designed for EWIS (fire & evacuation) installations where high SPL & speech intelligibility is required.

Emergency Warning & Intercommunications Systems (EWIS)

This speaker is designed for use in installations designed to deliver both verbal and tone announcements to occupants for evacuation and alarm conditions.

It is fitted with line monitoring capacitor and 4 way wire protect terminal connection.

About Redback® Speaker Drivers

Each custom designed speaker and transformer combination has been specifically engineered to ensure a wide frequency range and dispersion angle, plus a high sound pressure level (SPL) ensuring excellent music and speech intelligibility; which is highly desirable for emergency paging applications.

Redback® drivers exhibit optimum frequency response and efficiency for BGM, paging and EWIS applications. The transformers are wound on professional grade grain oriented steel cores for high efficiency and extended frequency response.

Each transformer is fitted with multiple power tapings which are selected via a tab on the side of the transformer.

Testing

Redback® drivers are subject to strenuous factory testing reducing the risk of unit failure or performance reduction over time. Each driver has a power rating well above the max tapping of the transformer, ensuring reliable operation and excellent longevity.

The Labour Saving One-Shot® Mounting System

Redback® "One-Shot®" speaker units install in seconds providing substantial labour cost savings for the professional installer compared to traditional mounting methods.

They simply snap fit to the ceiling by means of the integral pressure clips. The snap clip material is formulated to retain long service life strength and spring action, ensuring a firm vibration free fit to either gyprock tiles, mineral fibre tiles or fixed gyprock ceilings.

A neutral white RAL colour provides an architecturally unobtrusive finish to virtually any installation.

Installation Guidelines

The C 2142 is fitted with a 4 way wire protect screw terminal block. This is suitable for loop in, loop out cabling.

All One-Shot® speakers are designed for fast installation due to the integral pressure clips which grip to the reverse side of the ceiling tile. They are suit any 10-13mm ceiling tile, including gyprock, mineral fibre or fixed gyprock ceilings. Redback provide an optional tile support or 'ceiling pan' to minimise sag and vibration.

These pans fit inside the 't-bar' supports for the tile ceiling and provide a solid surface on which the One-Shot® clips secure to. Once the hole is cut, these simply slide up into the hole, the speaker is then pushed in until the clips release.

For 200mm (8") models we recommend a speaker hole of 246mm. This is easily cut using the T 2314 holesaw.

Product Guide

C 2142 200mm (8") 100V High Power 15W Ceiling Speaker



Dimensions & Transformer Detail

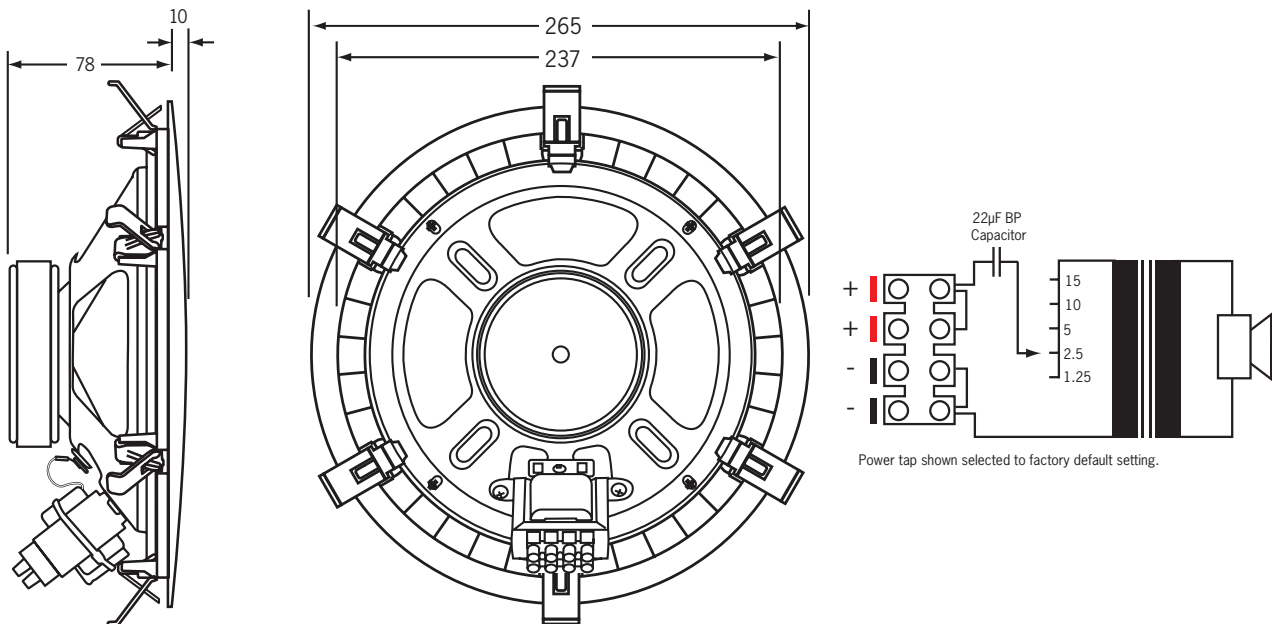

Specifications

Electrical

Power taps:	1.25, 2.5, 5, 10, 15W
SPL 1W @ 1m:	95dB @ 1kHz (+/- 2dB)
Frequency response:	55Hz-15kHz
Connection:	4 way terminal block + 22uF bipolar capacitor

Mechanical

Grille material:	High impact styrene
Driver construction:	Paper cone
Ceiling cutout:	246Ømm
Grille diameter:	265Ømm
Mounting depth:	88mm (including ceiling tile thickness)
Overall weight:	1.8kg
Colour:	White

Environmental

Operating temperature:	-25°C to +55°C
Relative humidity:	< 95%

Additional Installation Accessories

- C 2129** Steel ceiling tile support pan
- T 2314** Adjustable 40-270mm holesaw

Frequency Response (SPL 1W @ 1m)

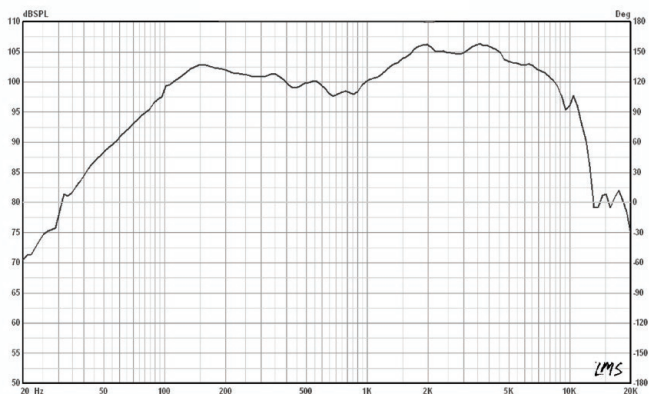

Architect Specifications

The speaker shall be of 200mm diameter and be fitted with a 100V transformer with power taps of 15W, 10W, 5W, 2.5W and 1.25W. It shall have a SPL of 95dB. It shall be fitted with a 4 way wire protect terminal block for cable connection and 22uf bipolar capacitor for line monitoring. The speaker shall be attached to a white ABS grill with One-Shot mounting mechanism. The speaker/grille combination shall be a Redback model C 2142.